

USER TO INSERT TOPO SURVEY

BENCH MARK DESCRIPTIONS

TBM #1 (IP): Elev = ????.??
Top of 1" X 2" wooden hub, marked by witness lath.

TBM #2: Elev = ????.??
Top of 1" X 2" wooden hub, marked by witness lath, near NW corner of building.

TBM #3: Elev = ????.??
Top of bolt in NW corner of concrete.

DESIGNER NOTE:

A SITE-SPECIFIC DESIGN IS REQUIRED AND SHALL INCLUDE A LOCATION MAP, PLAN VIEW, DIMENSIONS, SOIL CONDITIONS, HIGH WATER TABLE, DRAINAGE COMPONENTS, AND CONSTRUCTION SPECIFICATIONS NEEDED TO COMPLETE THE PROJECT.

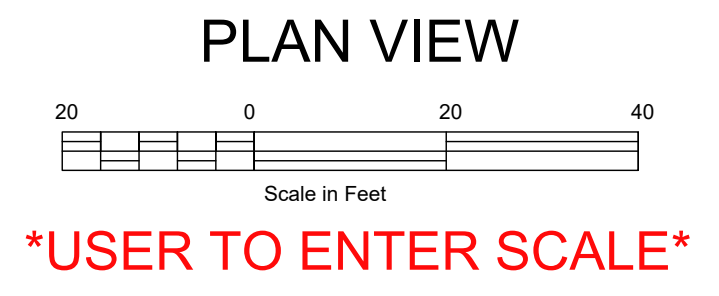

Roofing construction note:
Roofing material must be stored properly in accordance with the manufacturer's recommendations. Roofing material must be covered if it is stored outside to prevent premature deterioration.

Aluminum roofing may be used in lieu of steel. Roof shall be designed considering expansion and contraction and compatibility with other metals. The aluminum roofing shall have a minimum thickness of 0.018 inches and a maximum sheet length of 16 feet. Joints shall have sufficient overlap and fastened with stainless steel screws. The fastener holes shall be drilled and slotted and neoprene washers used.

All Glulam post must meet the following specifications:
3ply 2"x6" (5.25"x4.0625") Glulam $f_c=2050$ psi
4ply 2"x8" (7.0"x5.375") Glulam $f_c=2350$ psi

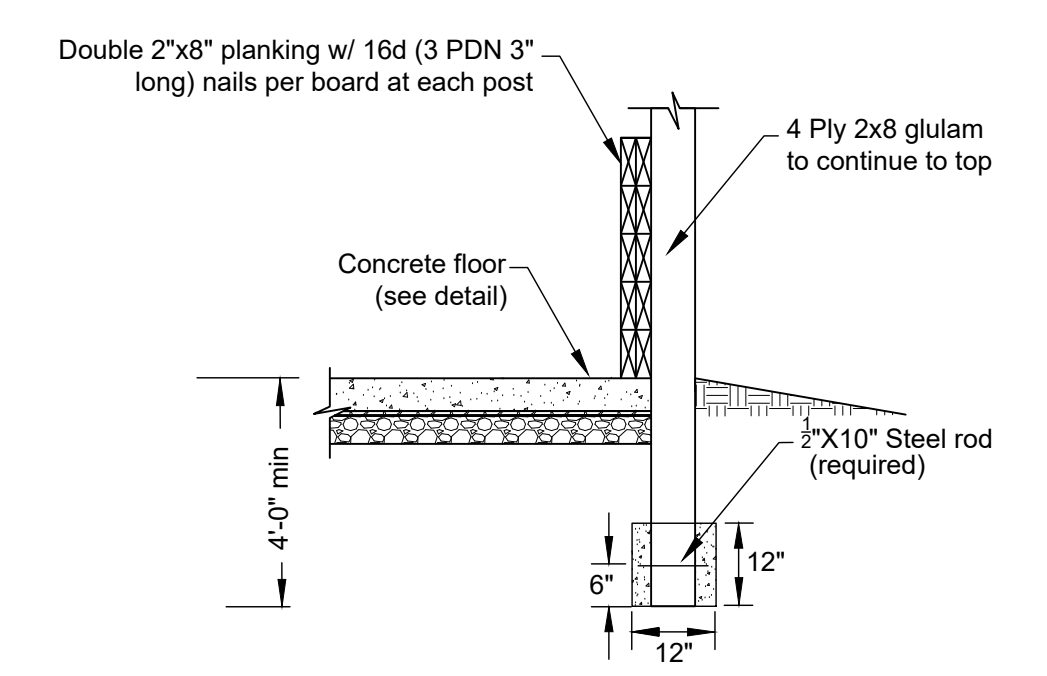
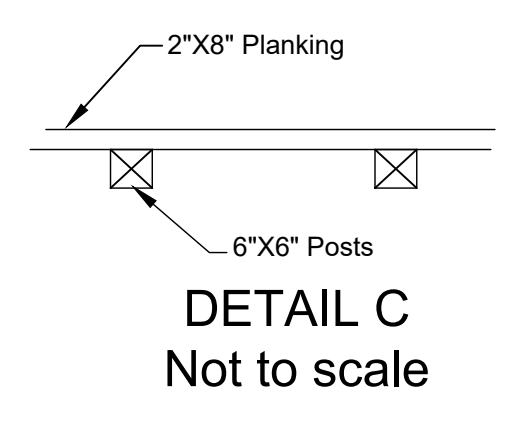
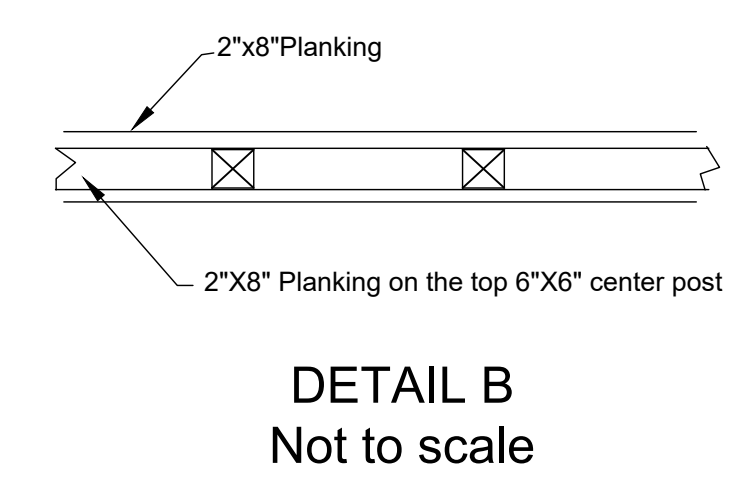
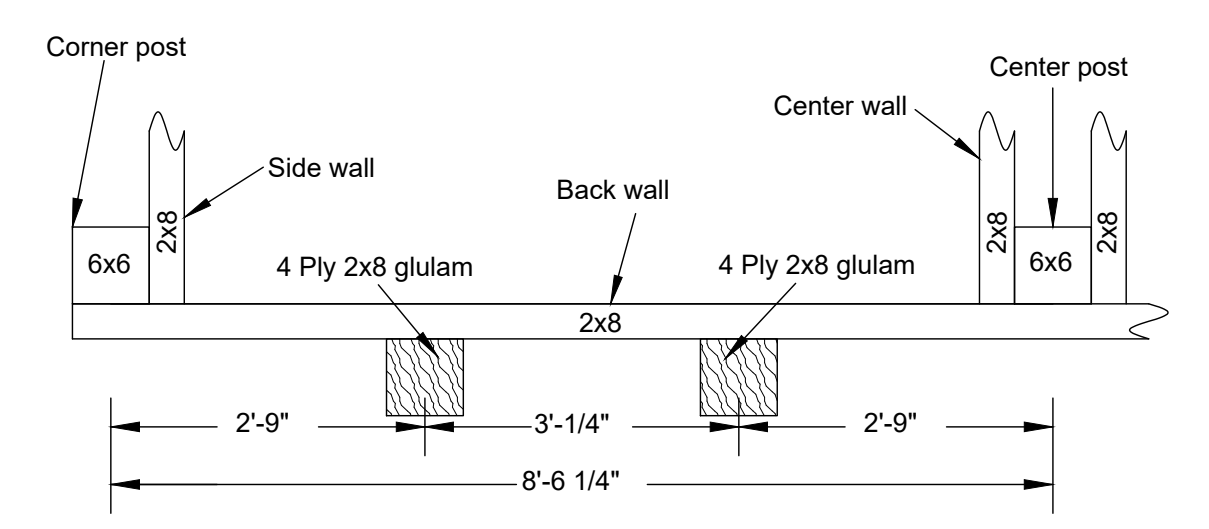
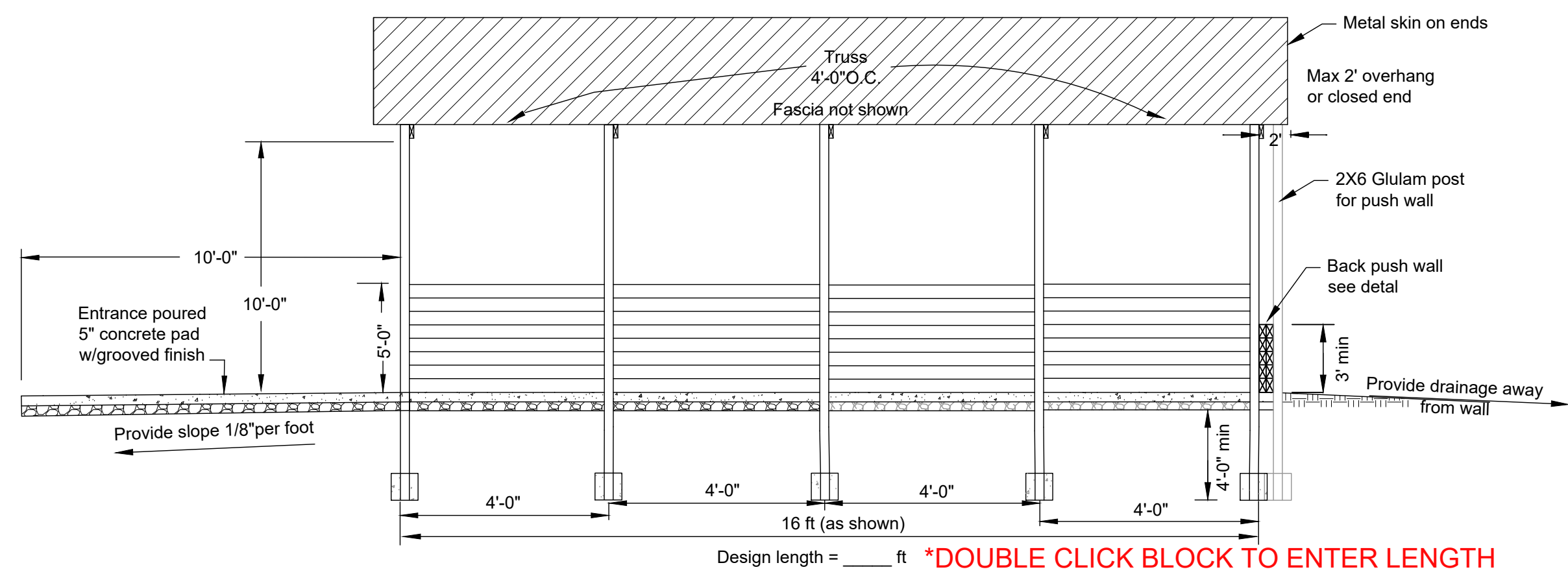
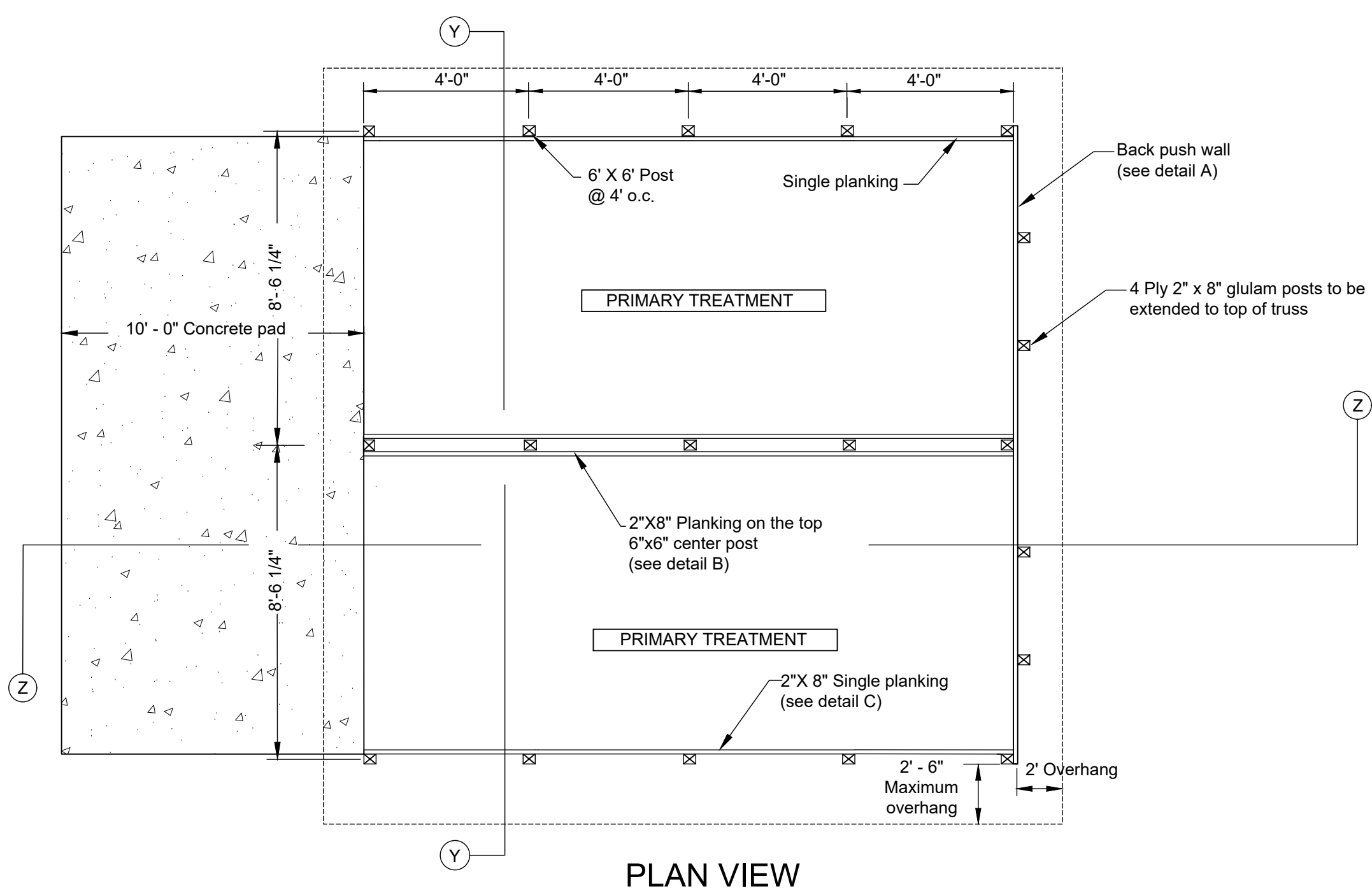
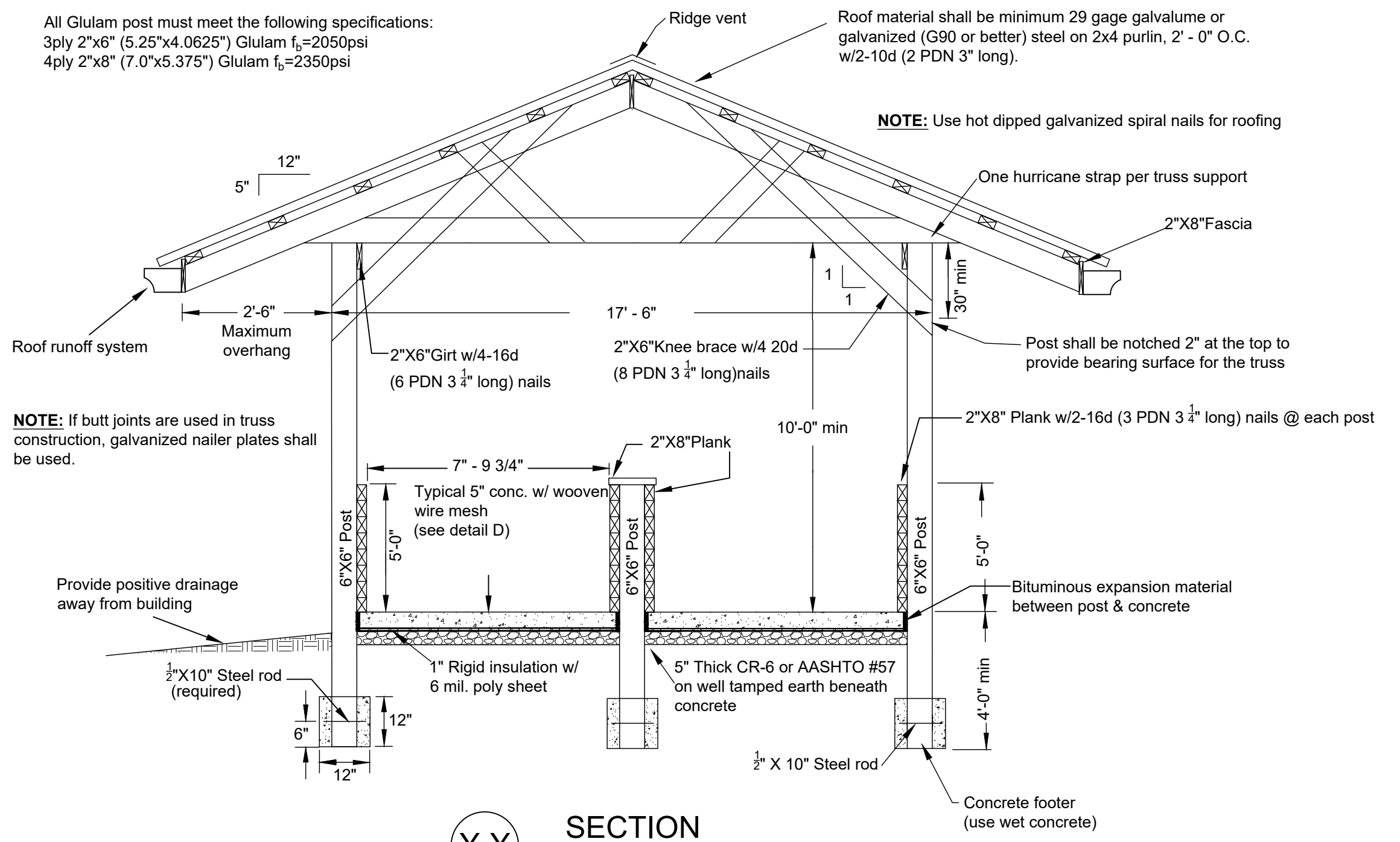

Length	# of Breeders/Roasters Up to	# of Broilers Up to
16'	85,000	105,000
24'	145,000	180,000
32'	205,000	260,000

Note: Sizing Chart is based on Chapter 10 Ag. Waste Handbook, VF = 1.75

Date	_____
Designed	_____
Drawn	_____
Checked	_____
Approved	_____

LANDOWNER - SITE NAME

COUNTY Soil Conservation District
JOB CLASS # _____
TRACT # _____



File Name
MD_0028_StandAloneChannelComposter.dwg

Drawing No.
MD_0028

Sheet 2 of 3

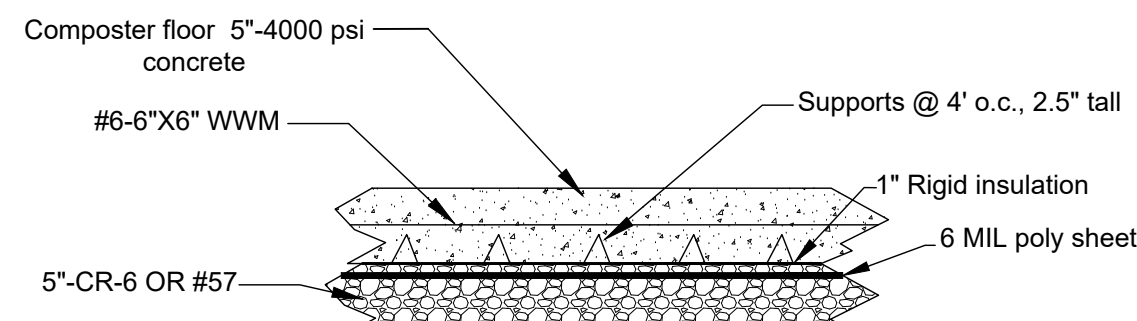

FLOOR DETAIL
Detail D
Not to scale

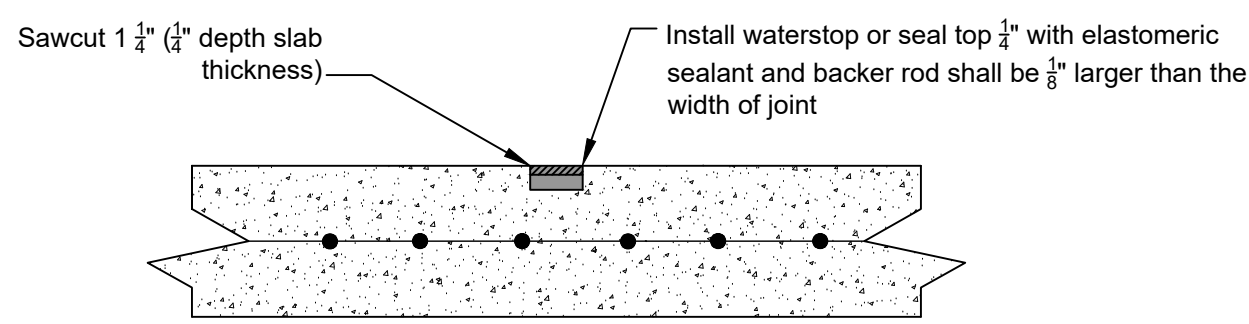

Note: Crack controlled joints are required for all pads. The perpendicular distance shall not be greater than 20ft.

CRACK CONTROL DETAIL
NOT TO SCALE

CONCRETE CONSTRUCTION SPECIFICATIONS
FLAT WORK ONLY – POULTRY HUA
Revised 07/21

- All materials and construction shall be in accordance with applicable NRCS Practice Standards and ACI-318.
- Any changes in the plans or specifications must be approved by the design approver prior to being made. Changes are to be reviewed by the landowner for concurrence.
- Concrete shall have Type IA or IIA cement, 28-day compressive strength of 4,000psi, 5% air entrainment and a slump of 3 to 5 inches. Air entrainment admixtures shall conform to ASTM C260.
- Reinforcing steel shall conform to ASTM A615, Grade 60 steel. All reinforcing material shall be free of dirt, loose rust, scale, oil, paint or other coatings. The steel shall be accurately placed into position, as shown on the plans, and securely restrained and blocked into position prior to placement of concrete. Insertion of steel into fresh concrete is not permitted. Reinforcement steel shall have a minimum of 2 inches of concrete cover against all forms and 3 inches against soil, unless otherwise shown on the plans. All other reinforcement steel splices shall overlap a minimum of 18 inches. Welded wire mesh shall conform to ASTM A1064 and overlap a minimum of 6 inches. The welding of reinforcing steel is not permitted.
- Waterstop will be used as shown on the plans and at all cold and construction joints. The type of waterstop will be approved by the field technician prior to use.
- Plasticizing or plasticizing and retarding admixtures may be used and shall conform to ASTM C1017 or ASTM C494 Types F or G.
- Concrete shall be delivered to the site and discharged completely into the forms within 90 minutes after the truck leaves the plant. This time shall be reduced to 45 minutes when the atmospheric temperature is over 90 degrees Fahrenheit. The concrete shall be maintained at a temperature below 90 degrees Fahrenheit during mixing, conveying and placement. Set retarding admixtures may be used to increase mixing time. Water reducing and/or retarding admixtures shall conform to ASTM C494 Types A, B, D, F or G.
- Concrete shall not be placed when the daily minimum atmospheric temperature is less than 40 degrees Fahrenheit unless facilities are provided to prevent the concrete from freezing. The concrete shall be protected from freezing for a minimum of 7 days or the concrete shall be kept at a temperature of 55 degrees Fahrenheit for a minimum of 3 days. Accelerating or water-reducing and accelerating admixtures shall be noncorrosive and conform to the requirements of ASTM C494, Types C and E. Cold weather concreting procedures shall conform to ACI-308.
- Concrete shall be kept continuously moist for the curing period after the placement of the concrete. Moisture may be applied by spraying or sprinkling as necessary to prevent the concrete from drying. Concrete shall not be exposed to freezing during the curing period. Curing compounds may be used in lieu of the application of moisture. Curing compounds shall conform to ASTM C309, Type 2.
- Defective concrete, honeycombed areas, voids left by the removal of tie rods, ridges on all concrete surfaces permanently exposed to view or exposed to water, shall be repaired immediately after the removal of forms. All voids shall be reamed and completely filled with quickset, non-shrink hydraulic cement.
- Concrete surfaces shall be screeded, floated, troweled and broom finished unless otherwise approved.
- Fill material under concrete shall be accomplished by placing maximum 8-inch lifts (before compaction). The lifts shall be compacted by the transversing of the entire surface by not less than one track of the equipment or by a minimum of four complete passes with a sheepsfoot, vibratory, or rubber tire roller. Compaction around structure (i.e. around pipes, adjacent to walls, etc.) shall be accomplished by placing fill in maximum 4-inch lifts (before compaction) and compacting by means of hand tampers or other manually directed compaction equipment. The technician shall determine if the moisture content is suitable for fill placement. The contractor shall make adjustments as directed by the technician. The method of compaction shall be approved prior to placement of fill material.

TIMBER CONSTRUCTION NOTES

8/2017

- All lumber below the fascia board level shall be preservative pressure treated Southern Yellow Pine, No.2 KD, 19% m.c. or better. All other lumber may be either Southern Yellow Pine or Spruce-Pine-Fir No. 2 or better unless specified otherwise. Protection such as clear preservative, paint, or pressure treatment shall be required for the plywood. Timber shall be pressure treated in accordance with the chart below.

Use Codes for Treated Building Materials	
Use Code for Ground or Manure Contact Lumber	UC4B
Use Code for all other Treated Lumber	UC4A

- Glulam posts used as columns shall be CCA pressure treated to a 0.60 retention factor a minimum 12" above the ground line on the ground contact end.
- All metal hardware and nails shall be stainless steel or hot-dip galvanized (HDG). Stainless steel shall be grade types 304 or 316. Hot dipped galvanized fasteners shall conform to ASTM A 153 and hot-dip galvanized connectors shall conform to ASTM Standard A 653 (Class G-185).
All fasteners, connectors, and any other metal contacting ACZA, ACQ or CA treated wood shall be stainless steel.
There may be additional products (other than stainless steel and hot-dip galvanized) which are suitable for use in treated wood except for the types listed in the note above. These screws and connectors have proprietary anti-corrosion technologies and are acceptable for treated wood exposed to moisture when used according to the hardware manufacturer's recommendations and **must be clearly marked "for use with" the type of treated wood being used.**
- All structural nail connections must be nailed with twisted or ring shank nails, unless otherwise as shown.
- Power driven nails (PDN) shall be 0.131 Diameter or larger, deformed shank, and helical (spiral) or annular (ring) type. The number and length of 0.131 diameter power driven nails is specified in parenthesis next to each connection. Pressure shall be applied to wood members to insure tight joints when using power driven nails. The head of the nail may not be countersunk more than 1/16" into the wood.

TRUSS DESIGN NOTES

Truss shown on the drawing is for illustration purposes only. Trusses shall be designed and approved by a licensed engineer. Truss manufacturer shall furnish all drawings for bracing required on trusses. Scissors trusses are acceptable with a level bearing plate.

Truss Design:

Span: 17'-6"
Slope: 5 in 12
Truss Spacing: 4' 0" on center
Overhang: 2'- 6"
Gable end trusses shall be sheathed

Truss Loadings: MINIMUM LOADINGS ARE SHOWN BELOW (COUNTY MAY REQUIRE HIGHER LOADINGS)

Top Chord Live Load, see listing below, Dead Load 5 psf
Bottom Chord Live Load 0 psf, Dead Load 5 psf

Garrett and Allegany Counties:
Top Chord Live Load 40 psf, Dead Load 5 psf

Washington County:
Top Chord Live Load 35 psf, Dead Load 5 psf

Baltimore, Carroll, Cecil, Frederick, Harford, Howard, Montgomery and Prince George's Counties:
Top Chord Live Load 30 psf, Dead Load 5 psf

Anne Arundel, Calvert, Caroline, Charles, Kent, Queen Anne's, St. Mary's and Talbot Counties:
Top Chord Live Load 25 psf, Dead Load 5 psf

Dorchester, Somerset, Wicomico, and Worcester Counties:
Top Chord Live Load 20 psf, Dead Load 5 psf

Date	_____
Designed	_____
Drawn	_____
Checked	_____
Approved	_____

LANDOWNER – SITE NAME

COUNTY Soil Conservation District

JOB CLASS #

TRACT #

_____, Maryland

United States Department of Agriculture
Natural Resources Conservation Service

File Name	MD_0028_StandAloneChannelComposter.dwg
Drawing No.	MD_0028
Sheet	3 of 3