

There will be no changes in specification, dimensions, or materials unless approved by the engineer responsible for this drawing.

The drawings are prepared cooperatively by the Natural Resources Conservation Service (NRCS) for the named landowner. Construction found not in accordance with these drawings and specifications shall violate the cooperative agreement and all drawings, specifications, and quantities estimate shall immediately be returned to the local NRCS office.

The contractor/owner is to notify the SOIL CONSERVATION DISTRICT at least 72 hours prior to construction to schedule a pre-construction meeting, facilitate any scheduling, layout, or preliminary mobilization necessary to ensure proper construction inspection to enable appropriate certification of the project. A conservation technician shall verify cut/grade stakes at the contractors request.

The owner/operator gives permission for Maryland Department of the Environment (MDE) and U.S. Army Corps of Engineers (COE) inspection.

It is the landowner's responsibility to obtain all county, state, and federal permits that may be needed, and to maintain this structure and related regulations.

All excavation and methods of construction shall be in accordance with the Maryland Occupational Safety and Health (MOSH) standards as set forth in the latest version of the code of Maryland regulations.

# LANDOWNER - SITE NAME

## 441 IRRIGATION SYSTEM, MICRO



**Know what's below.  
Call before you dig.**

\*The Soil Conservation District makes no representation as to the existence or Non-existence of any utilities at the construction site. Shown on these construction drawings are those utilities which have been identified. It is the responsibility of the landowners or operators and contractors to assure themselves that no hazard exists or damage will occur to utilities\*

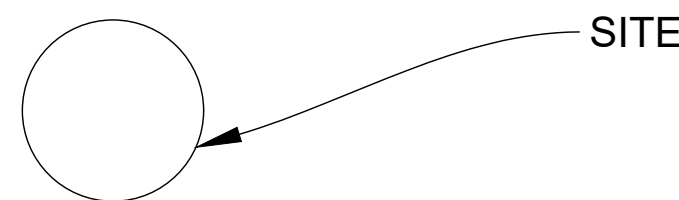
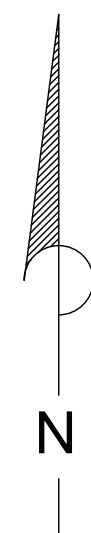

**GENERAL NOTES:**

- Please contact the SOIL CONSERVATION DISTRICT AT PHONE # at least 3 days prior to construction to arrange a pre-construction meeting
- A conservation technician shall set cut/grade stakes at the contractors request
- A conservation technician must be present at the time of pipe installation, if required

**CRITICAL INSPECTION ITEMS FOR MICROIRRIGATION SYSTEM**  
6/18/2021

1. The landowner will arrange for a pre-construction meeting between the contractor, NRCS and landowner to review the plans, standards and specifications prior to the start of construction.
2. There will be no changes in specifications, dimensions, or materials unless approved by the engineer responsible for this drawing.
3. The drawings are prepared cooperatively by the Natural Resources Conservation Service for named owner/operator. Construction found not in accordance with these drawings and specifications shall violate the cooperative agreement and all drawings, specifications, and Quantities Estimate shall immediately be returned to the local NRCS office.
4. The following is a list of items that must be inspected by the Technician-in-Charge. If cost share is involved, payment may be forfeited if the Technician-in-Charge does not inspect all of the below:
  - Preconstruction Meeting Date: \_\_\_\_\_ Initials: \_\_\_\_\_
  - Verify layouts Date: \_\_\_\_\_ Initials: \_\_\_\_\_
  - Pipe Placement:
    - Inspect Trench and Grades Date: \_\_\_\_\_ Initials: \_\_\_\_\_
    - Pipe Placement Date: \_\_\_\_\_ Initials: \_\_\_\_\_
    - Pipe Material and Size – Main and submains Date: \_\_\_\_\_ Initials: \_\_\_\_\_
    - Pipe Material and Size – Laterals Date: \_\_\_\_\_ Initials: \_\_\_\_\_
    - Thrust Block installation Date: \_\_\_\_\_ Initials: \_\_\_\_\_
    - Emitter Size, Type and Spacing Date: \_\_\_\_\_ Initials: \_\_\_\_\_
  - Pump Installation:
    - Type and Size verified Date: \_\_\_\_\_ Initials: \_\_\_\_\_
    - Connections verified Date: \_\_\_\_\_ Initials: \_\_\_\_\_
    - Backflow preventer valve Date: \_\_\_\_\_ Initials: \_\_\_\_\_
    - Pressure release valve Date: \_\_\_\_\_ Initials: \_\_\_\_\_
  - Final Grading Date: \_\_\_\_\_ Initials: \_\_\_\_\_
  - All disturbed areas seeded and mulched Date: \_\_\_\_\_ Initials: \_\_\_\_\_
  - Other items shown on the plans Date: \_\_\_\_\_ Initials: \_\_\_\_\_

**REVISED 1/1/2022**

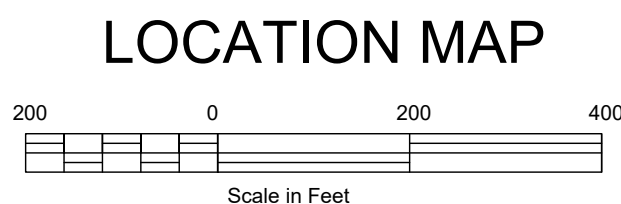

USER TO INSERT SHEET LIST TABLE

ALL CONSTRUCTION SHALL BE IN ACCORDANCE WITH THE LATEST NRCS SPECIFICATIONS FOR EACH CONSERVATION PRACTICE LISTED ON THE PLANS. IF NOT PROVIDED IN THE PLANS AND SPECIFICATIONS, THE SPECIFICATIONS FOR EACH CONSERVATION PRACTICE CAN BE FOUND IN SECTION IV OF THE MARYLAND ELECTRONIC FIELD OFFICE TECHNICAL GUIDE (eFOTG) LOCATED AT: <https://efotg.sc.gov.usda.gov/#/state/MW> UNDER 'Conservation Practice Standards & Support Documents'.

**AS-BUILT STATEMENT**  
THE CONSERVATION PRACTICE(S) MEETS OR EXCEEDS NRCS STANDARDS AND SPECIFICATIONS

INSPECTED BY \_\_\_\_\_ SIGNATURE \_\_\_\_\_ DATE \_\_\_\_\_

CONSTRUCTION APPROVAL \_\_\_\_\_ SIGNATURE \_\_\_\_\_ DATE \_\_\_\_\_

VERIFIED DISTRICT CONSERVATIONIST \_\_\_\_\_ SIGNATURE \_\_\_\_\_ DATE \_\_\_\_\_

AS BUILT CONTRACT ITEMS:

PRACTICE	Reportable Amount	Contract Amount

USER TO ENTER PRACTICES

**OWNER/CONTRACTOR STATEMENT**

I CERTIFY THAT THIS DESIGN HAS BEEN EXPLAINED TO ME BY A REPRESENTATIVE OF THE COUNTY SOIL CONSERVATION DISTRICT, AND I UNDERSTAND THE CONTENTS, ALL CONSTRUCTION WILL BE DONE ACCORDING TO THESE PLANS AND SPECIFICATIONS, I FURTHER UNDERSTAND THAT ALL CONSTRUCTION WILL BE UNDER THE INSPECTION OF THIS OFFICE.

OWNER/OPERATOR SIGNATURE \_\_\_\_\_ DATE \_\_\_\_\_

CONTRACTOR'S SIGNATURE \_\_\_\_\_ DATE \_\_\_\_\_

**MATERIALS LIST**  
\* For bidding purposes only

**SITE DATA:**

LANDOWNER INFORMATION: \_\_\_\_\_ STREAM CLASSIFICATION: \_\_\_\_\_

CONTACT PERSON: \_\_\_\_\_ STREAM CLOSURE DATE(S): \_\_\_\_\_

**SITE DETAILS:**

Total Disturbed Acres = ± \_\_\_\_\_

Total Disturbed Sqft = ± \_\_\_\_\_

Construction supervision by NRCS/MDA/SCD personnel.  
Landowner's permission for MDE and COE inspection.

Date \_\_\_\_\_

Designed \_\_\_\_\_

Drawn \_\_\_\_\_

Checked \_\_\_\_\_

Approved \_\_\_\_\_

LANDOWNER - SITE NAME

#####

COUNTY Soil Conservation District

JOB CLASS # \_\_\_\_\_

TRACT # \_\_\_\_\_

United States Department of Agriculture

USDA

Natural Resources Conservation Service

File Name MD\_0060\_IrrigationMicro.dwg

Drawing No. MD\_0060

Sheet 1 of 5

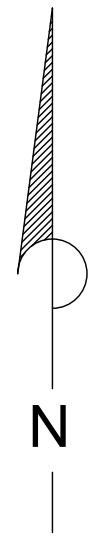

**BENCH MARK DESCRIPTIONS**

- TBM #1 (IP): Elev = ????.??  
Top of 1" X 2" wooden hub, marked by witness lath.
- TBM #2: Elev = ????.??  
Top of 1" X 2" wooden hub, marked by witness lath, near NW corner of building.
- TBM #3: Elev = ????.??  
Top of bolt in NW corner of concrete.

\*USER TO INSERT TOPO SURVEY ALONG WITH AERIAL MAP\*

\*USER TO ENTER REQUIRED INFORMATION\*

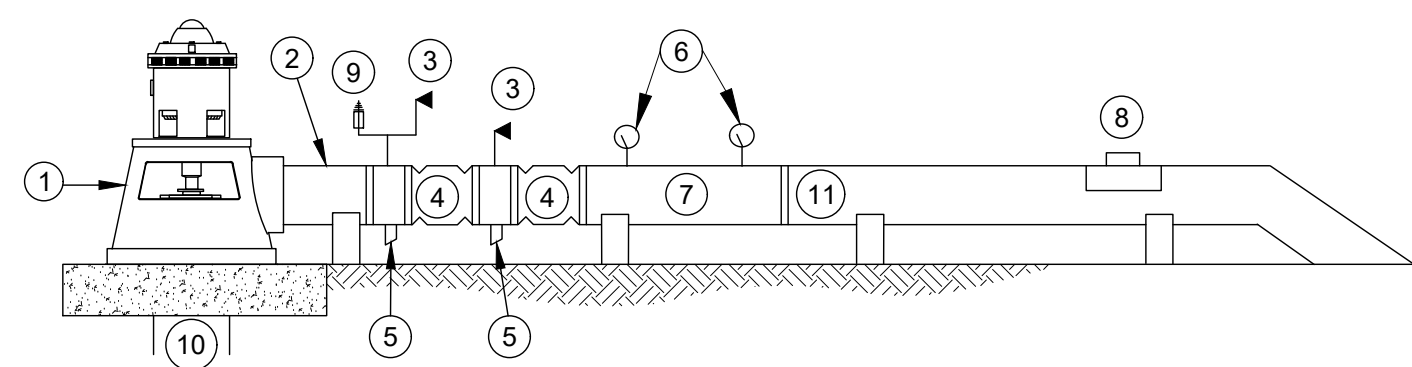

- 1 Pump and motor \_\_\_\_\_ gpm at \_\_\_\_\_ psi @ filter discharge
- 2 Pump discharge pipe: diameter \_\_\_\_\_ inches
- 3 Air-vacuum release valve: type \_\_\_\_\_ diameter \_\_\_\_\_ inches
- 4 Check valve
- 5 Low pressure drain
- 6 Pressure gauge
- 7 Filter type \_\_\_\_\_
- 8 Flow meter
- 9 Pressure release valve: dia \_\_\_\_\_ inch, pressure set at \_\_\_\_\_ psi
- 10 Source of water \_\_\_\_\_
- 11 Chemical injection point

**PUMP SCHEMATIC**  
Not to scale

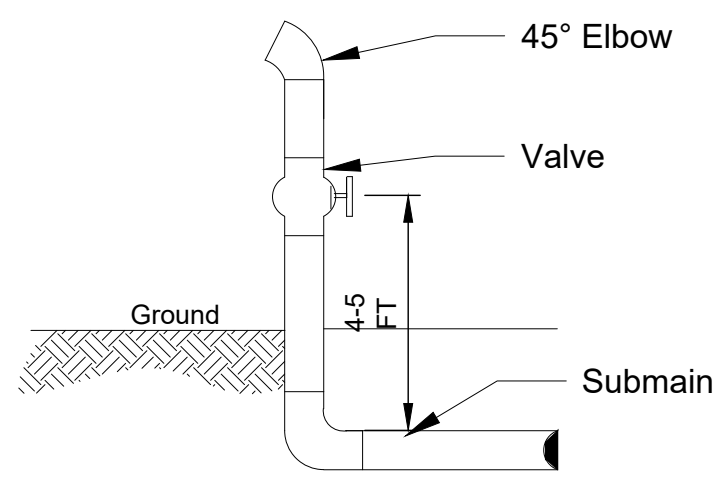

**SUBMAIN FLUSHOUT DETAIL**  
Not to scale

**PLAN VIEW**

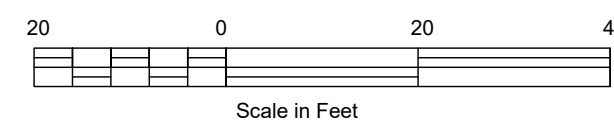

\*USER TO ENTER REQUIRED INFORMATION\*

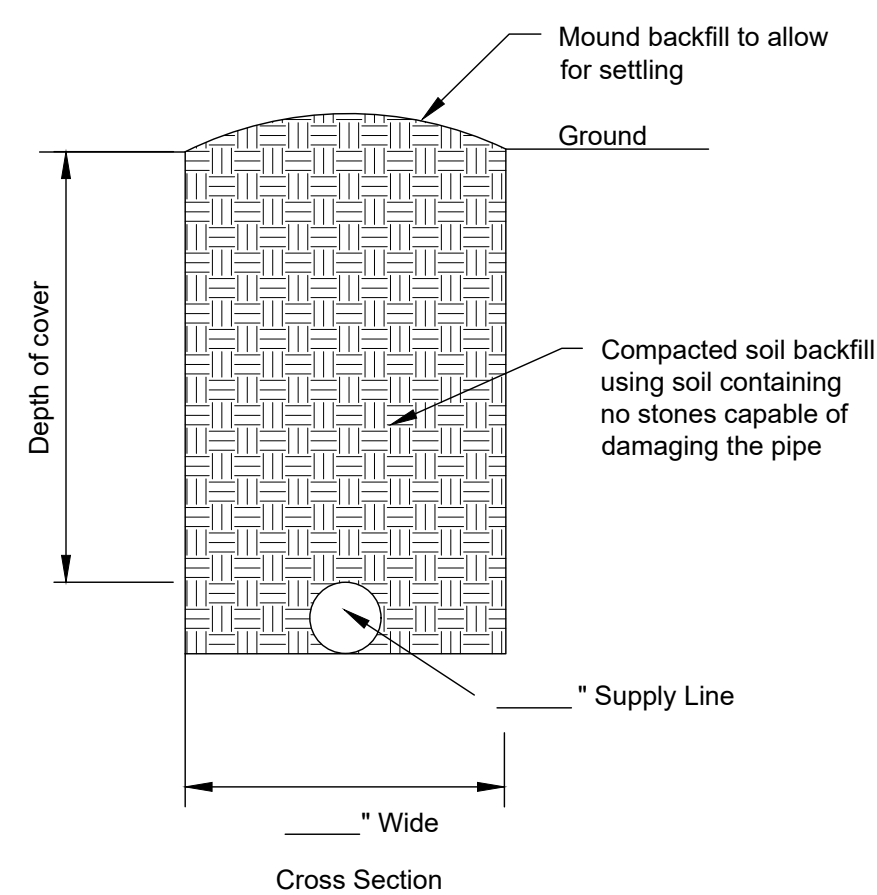

**TYPICAL CROSS SECTION OF MINIMUM DEPTH OF PIPE COVER**  
Not to scale

- \_\_\_\_\_ No. of Trees
- \_\_\_\_\_ Tree Spacing
- \_\_\_\_\_ Row Spacing
- \_\_\_\_\_ Acres Irrigated

**LEGEND**

- EXISTING PUMP:
- WELL:
- PIPELINE, MAIN (M), SUBMAIN (SM), AND MANIFOLD:
- LATERAL, L:
- CONTOUR LINES:
- FIELD BOUNDARY:
- TREE:
- THRUST BLOCK:
- VALVES:
  - FLUSH:
  - SHUTOFF:
  - AIR RELEASE:

Date	_____
Designed	_____
Drawn	_____
Checked	_____
Approved	_____

**LANDOWNER - SITE NAME**  
#####  
COUNTY Soil Conservation District  
JOB CLASS # \_\_\_\_\_

TRACT # \_\_\_\_\_



File Name  
MD\_0060\_IrrigationMicro.dwg

Drawing No.  
MD\_0060

Sheet 2 of 5

**GENERAL NOTES**

1. Installation and materials shall meet the Natural Resources Conservation Service (NRCS) conservation practice and specifications Irrigation System, Microirrigation code 441, and Irrigation Pipeline code 430. Any plan modification shall be clearly indicated on this drawing and shall be approved by the NRCS prior to installation.
2. The installer shall certify that his/her installation complies with the standards and specifications listed above and as specified on these plans. The certification shall identify the manufacturer and markings of the pipe used. The installer (when other than the owner) shall furnish a written guarantee to the owner that protects the owner against defective workmanship and materials for no less than one year. Copies shall be provided for NRCS records.
3. All permits needed to install and operate this system shall be the responsibility of the owner.
4. The irrigation system shall be operated in accordance with the irrigation water management plan.

**MATERIAL NOTES \*USER TO ENTER INFORMATION\***

1. Pipe material- mains and submains.

Nom Pipe Size (in)	PIP OR IPS	SDR No.	Material (PVC, 1120, etc.)	Pressure Rating (psi)	Inside Diameter (in)	Length (ft)

Laterals- tubing shall withstand a working pressure based on manufacturer's data. **\*USER TO ENTER INFORMATION\***

Working Pressure (psi)	Inside Diameter (in/mm)	Length (ft)

2. The filter net opening diameter shall not exceed \_\_\_\_, or as recommended by the emitter manufacturer when available.

3. Emitters: **\*USER TO ENTER INFORMATION\***

Irrigation Unit	
Discharge Rate GPM / at psi	
Orifice Size (in)	
Wetted Diameter (ft)	
Spacing (ftxft)	
Total No. Emitters	
Riser Length (in)	
Manufacturer/Brand	
Plant Spacing	
Row Spacing	

4. Appurtenances (Flush valves, gate valves, etc.) **\*USER TO ENTER INFORMATION\***

Type	Size	Number	Location

**CONSTRUCTION NOTES**

**\*USER TO ENTER INFORMATION\***

1. See conservation practice standard Irrigation Pipeline code 430 specifications for additional construction requirements.

Depth of Cover For Pipeline- Mains and Submains							
Diameter (in)							
Depth of Cover (in)							

2. Laterals (Tubing):  
 \_\_\_\_ installed above ground and anchored on \_\_\_\_ ft intervals \_\_\_\_ installed underground at a depth of \_\_\_\_ in (may be lesser depth at base of tree)
3. Emitters shall be stabilized to maintain spray integrity.
4. Pressure relief valves shall be set to open at a pressure not greater than 5 psi about the pressure rating of the pipe. Pressure relief valves shall be marked at the pressure they start to open. Adjustable valves shall be sealed or otherwise altered to prevent changing the pressure marked on the valve.
5. Plastic pipe exposed to direct sunlight shall be made of ultraviolet resistant materials or protected by coating or shielding.
6. Pipelines crossing roads, canals, etc., shall be protected and/or supported.
7. Air-release valves shall be installed on all summits, which are not permanently and adequately vented to the atmosphere, and all summits encountered during construction although not shown on the drawings. Air-release valves at summits shown on the drawings may be eliminated when trench construction removes the summit.
8. Backflow prevention device shall be installed where required by law. (toxic) (non-toxic) chemicals (will) (will not) be injected into the system.
9. Flush valves shall be installed at the end of all submains.
10. Joints and connections shall be installed in conformance with conservation practice standard, Irrigation Pipeline, Code 430. Emitter connections to the lateral lines (tubing) shall be in accordance with the manufacturer's recommendations.
11. The head loss through a clean filter shall not exceed 5 psi. Head loss through sand separators shall be based on manufacturer's data and recommendations.
12. Pump, power unit, filter, chemical injectors and other appurtenances shall be installed on a firm base and in proper alignment. Installation shall be in accordance with the manufacturer's recommendations and all pertinent safety codes.
13. The irrigation system shall be tested for design operating pressures, discharge rates, leakage and proper functionality. During the initial start-up the pipelines and laterals shall be flushed for sufficient time to remove any sediment or foreign material prior to the placement of end plugs or closure of flush valves.

**OPERATION NOTES**

**\*USER TO ENTER INFORMATION\***

1. System design capacity shall be based on \_\_\_\_\_ GPM / Acre

Working Pressure (psi)	Inside Diameter (in/mm)	Length (ft)

2. Adjust outlet valves so that water in all the furrows reaches the ends.
3. Remarks: \_\_\_\_\_  
 Open all valves before starting the pump:

**CONSTRUCTION CHECK**

**\*USER TO ENTER INFORMATION\***

Date installed: \_\_\_\_\_ Contractor: \_\_\_\_\_

Final Construction check by: \_\_\_\_\_ Date: \_\_\_\_\_

The Practice meets NRCS Practice Standards and Specifications.

Certified by: \_\_\_\_\_ Date: \_\_\_\_\_  
 (signature)

LANDOWNER - SITE NAME

#####  
 COUNTY Soil Conservation District

JOB CLASS #

TRACT #



File Name  
 MD\_0060\_IrrigationMicro.dwg

Drawing No.  
 MD\_0060

Sheet 3 of 5

Date	Designed	Drawn	Checked	Approved

\_\_\_\_\_, Maryland

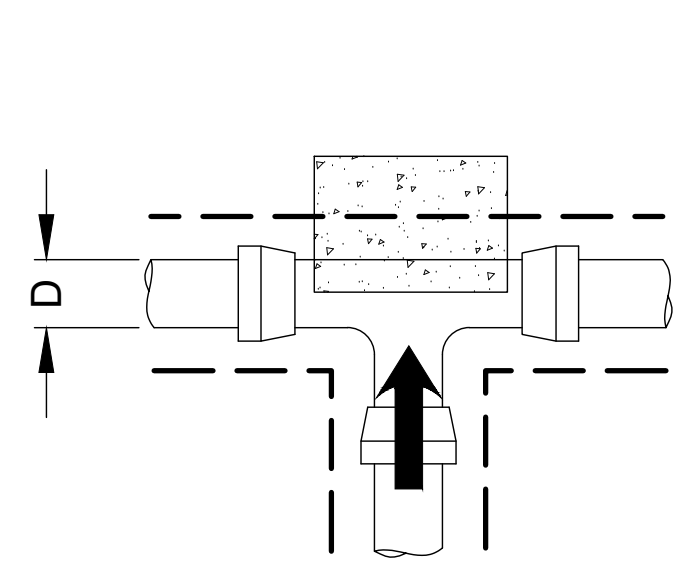

TYPE A  
(SEE SECTION A)  
n.t.s.

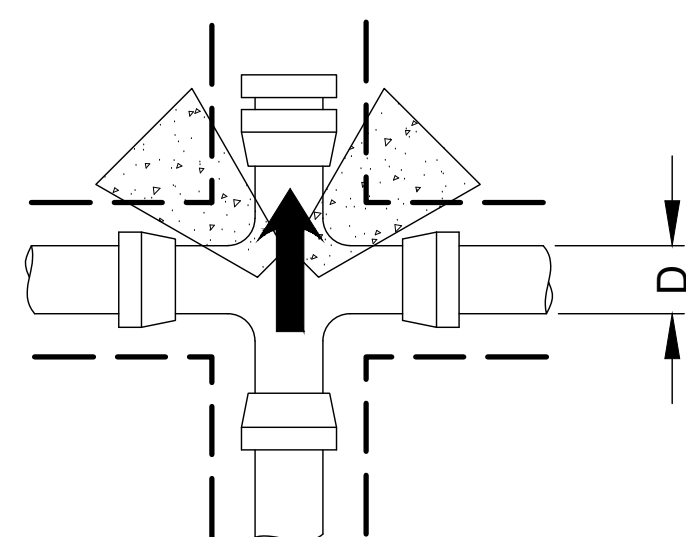

TYPE B  
(SEE SECTION A)  
n.t.s.

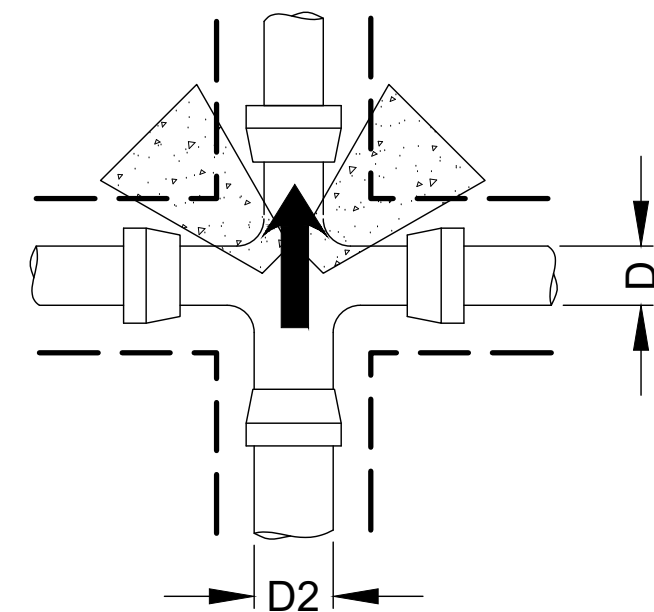

TYPE C  
(SEE SECTION A)  
n.t.s.

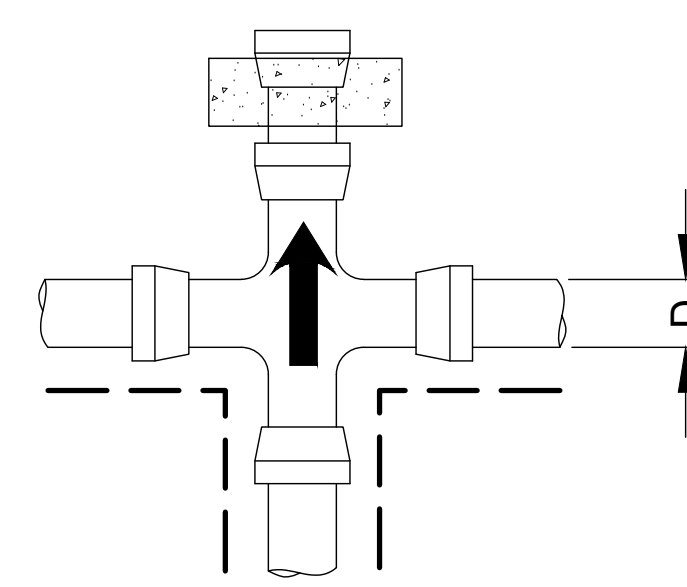

TYPE D  
(SEE SECTION B)  
n.t.s.

General Notes

1. Thrust block must be formed against a solid hand excavated trench wall undamaged by mechanical equipment.
2. All thrust blocks shall be constructed of concrete, and the space between the pipe and trench wall shall be filled with concrete to a height not less than the outside diameter of the pipe or as specified by manufacturer.
3. The concrete shall have a compression strength of at least 2000 psi.
4. The concrete mix shall be one part cement, two parts washed sand and four parts gravel.
5. The thrust blocks shall be constructed so that the bearing surface is in direct line of anticipated thrust.

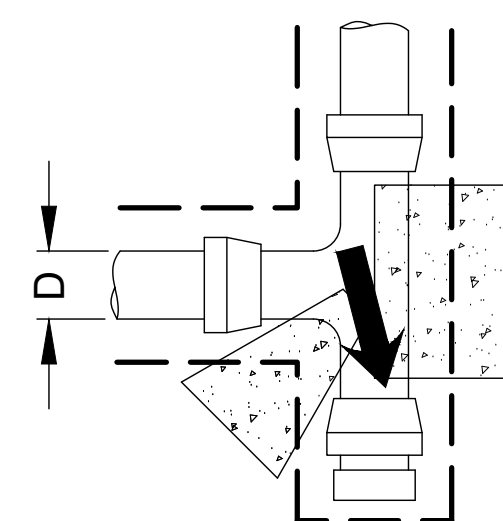

TYPE E  
(SEE SECTION A)  
n.t.s.

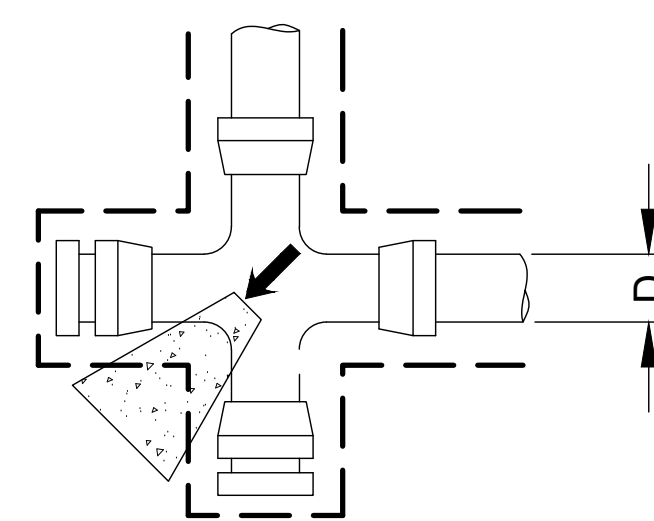

TYPE F  
(SEE SECTION A)  
n.t.s.

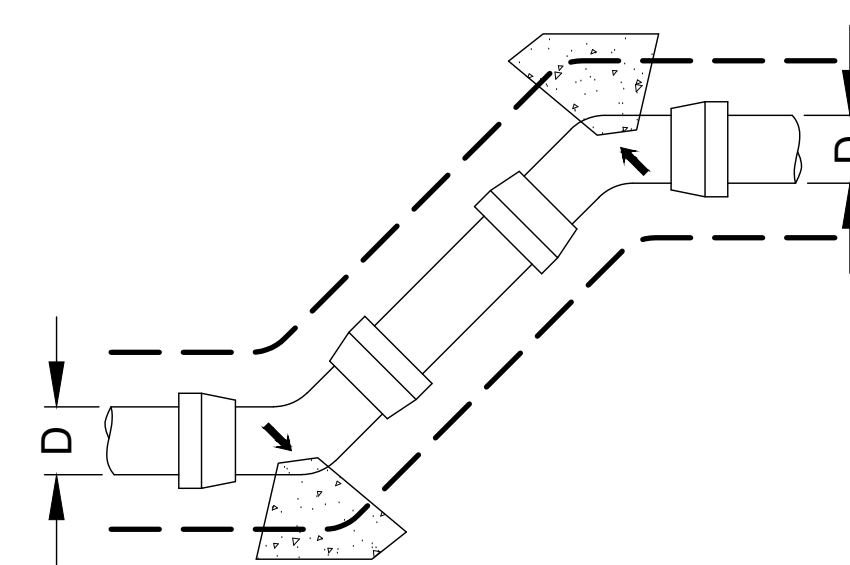

TYPE G  
(SEE SECTION A)  
n.t.s.

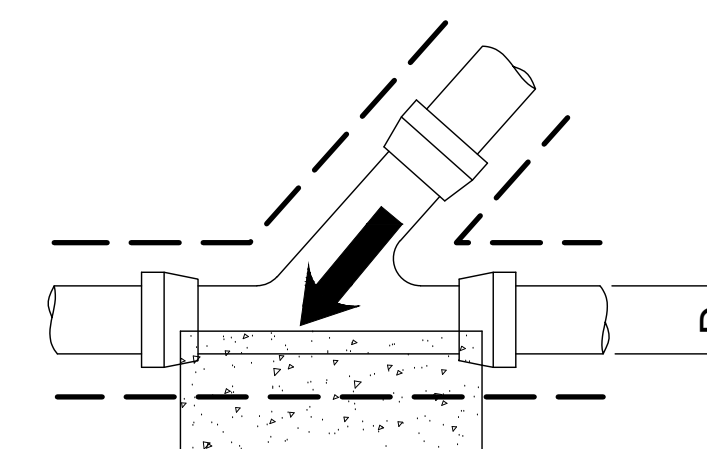

TYPE H  
(SEE SECTION A)  
n.t.s.

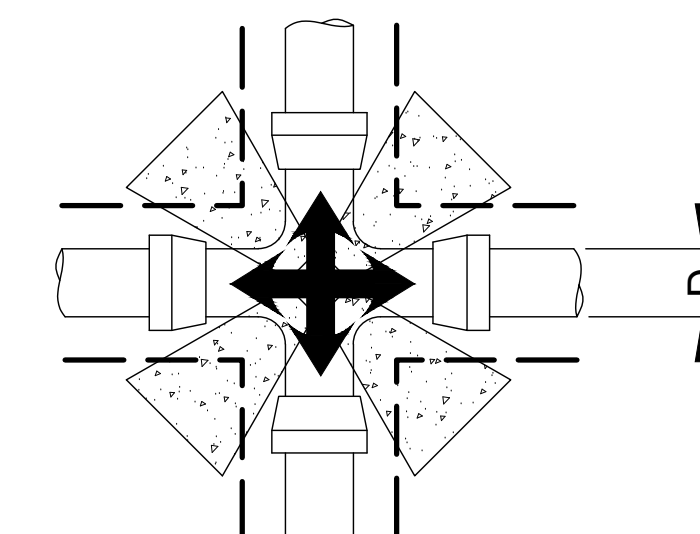

TYPE I  
(SEE SECTION A)  
n.t.s.

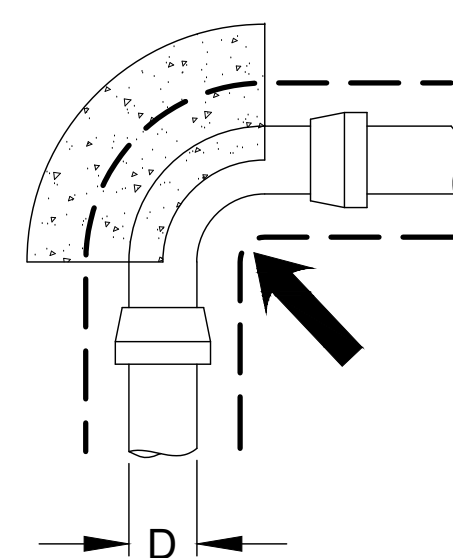

TYPE J  
(SEE SECTION A)  
n.t.s.

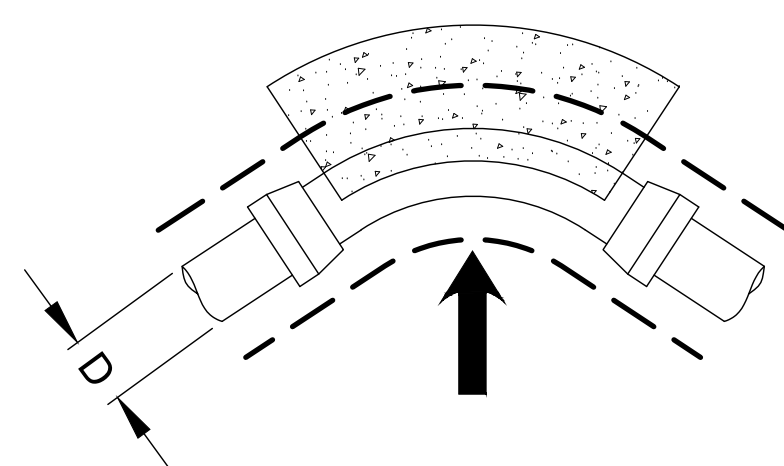

TYPE K  
(SEE SECTION A)  
n.t.s.

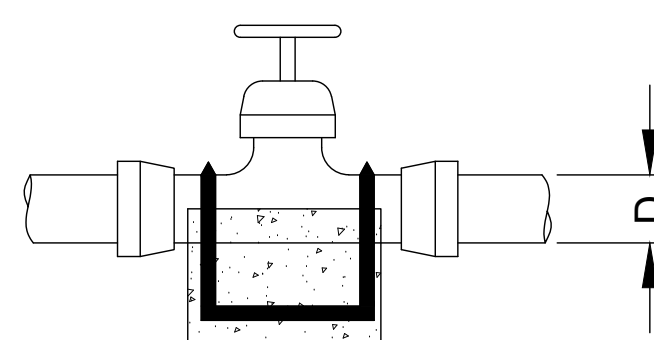

TYPE L  
(SEE SECTION A)  
n.t.s.

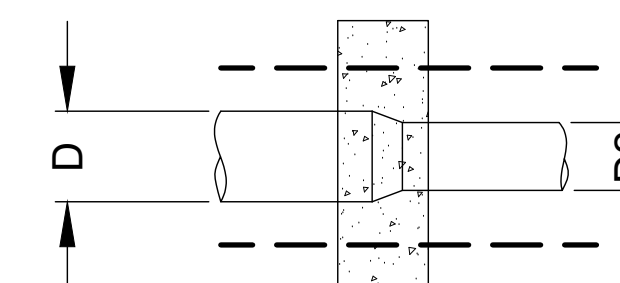

TYPE M  
(SEE SECTION B)  
n.t.s.

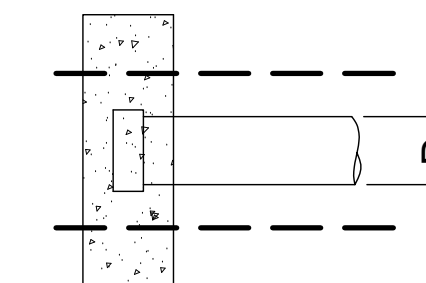

TYPE N  
(SEE SECTION B)  
n.t.s.

Note: This standard drawing requires supporting technical documentation prior to use and must be adapted to the specific site. Arrows indicate direction of anticipated thrust.

**\*USER TO ENTER INFORMATION\***

Thrust Block Specifications					
Location	Type	D(in)	D2(in)	Length(ft)	Width(ft)

Note: Thrust block volumes are based on a depth of 1ft multiplied by thrust block surface area (Length x Width).

Thrust Block Details

Type A.	Thru line connection, tee
Type B.	Thru line connection, cross used as tee
Type C.	Change line size, cross used as reducer
Type D.	Change line size, reducer
Type E.	Direction change, tee used as elbow
Type F.	Direction change, cross used as elbow
Type G.	Direction change
Type H.	Thru line connection, wye
Type I.	Direction varies, cross used
Type J.	Direction change, 90 degree elbow used
Type K.	Direction change, 45 degree elbow used
Type L.	Valve
Type M.	Change line size, reducer
Type N.	End cap

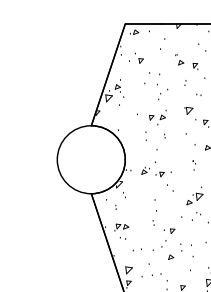

SECTION A  
Not to scale

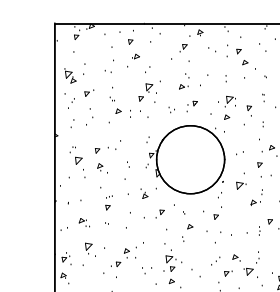

SECTION B  
Not to scale

Legend

--- Trench Walls

Date \_\_\_\_\_

Designed \_\_\_\_\_

Drawn \_\_\_\_\_

Checked \_\_\_\_\_

Approved \_\_\_\_\_

LANDOWNER - SITE NAME

####

COUNTY Soil Conservation District

JOB CLASS #

TRACT #

United States  
Department of  
Agriculture

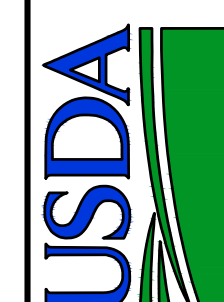

Natural Resources  
Conservation Service

File Name  
MD\_0060\_IrrigationMicro.dwg

Drawing No.  
MD\_0060

Sheet 4 of 5

**CONSTRUCTION SPECIFICATIONS  
MD 430 – IRRIGATION PIPELINE**

**1. SCOPE**

The work shall consist of furnishing materials and installing all components of an irrigation pipeline, as outlined in this specification and the drawings.

**2. MATERIALS**

All materials used shall conform to the quality and grade noted on the plans or as otherwise listed below:

**Plastic Pipe.** Plastic pipe shall meet or exceed the requirements specified in the listed ASTM Specifications. Polyethylene pipe materials shall be Class C (black) as specified in ASTM D1248.

**Pipe Requirements.** All pipe installed under this standard shall be pressure rated for water.

Plastic pipe manufactured, tested, and marked to meet one of the following ASTM specifications shall be acceptable.

**ASTM Standard Specifications for:**

D1785 Polyvinylchloride (PVC) Plastic Pipe, Schedules 40, 80, and 120

D2241 Polyvinylchloride (PVC) Pressure-rated Pipe (SDR-Series)

D2740 Polyvinylchloride (PVC) Plastic Tubing

D1527 Acrylonitrile-Butadiene-Styrene (ABS) Plastic Pipe, Schedules 40 and 80

D2282 Acrylonitrile-Butadiene-Styrene (ABS) Plastic Pipe (SDR-PR)

D2104 Polyethylene (PE) Plastic Pipe, Schedule 40

D2239 Polyethylene (PE) Plastic Pipe, (SIDR-PR) Based on Controlled Inside Diameter

D2447 Polyethylene (PE) Plastic Pipe, Schedules 40 and 80, Based on Outside Diameter

D2737 Polyethylene (PE) Plastic Tubing

D3035 Polyethylene (PE) Plastic Pipe (DR-PR), Based on Controlled Outside Diameter

The specific pipe size, required pressure rating minimum SDR, pipe schedule, and other requirements pertinent to the job shall be as shown on the drawings. Pipe conforming to other ASTM or AWWA specifications and meeting or exceeding specified requirements for this job may be used if approved by the responsible engineer.

**3. MARKINGS**

Markings on the pipe shall include the following which shall be spaced at intervals no more than 5 feet:

1. Nominal pipe size (eg.: 2 inches)
2. Type of plastic pipe material, by designation code (e.g.: PVC 1120)
3. Pressure rating, lb/in.<sup>2</sup> 230 C (73.4°F) (e.g.: 160 lb/in<sup>2</sup>)
4. Specification designation with which the pipe complies:
  - a. For IPS-size, the ASTM designation (For example D-2241). Pipe meeting one of the ASTM designations listed for IPS-size pipe and intended for the transport of potable water shall also be marked with the seal of a recognized laboratory making the elevation for this purpose.
  - b. For plastic irrigation pipe, the designation PIP.
5. Manufacturer's name (or trademark) and code.

**4. FITTINGS, COUPLINGS, AND JOINTS**

All fittings, couplings and joints shall meet or exceed the same strength requirements as those of the pipe and shall be made of material that is recommended for use with the pipe. Solvent cement and rubber gasket joints shall be assembled according to the manufactures recommendations.

**5. INSTALLATION**

**Minimum Depth of Cover.** Pipe shall be installed at sufficient depth below the ground surface to provide protection from hazards imposed by traffic crossings, farming operations, freezing temperatures, or soil cracking. The minimum depth of cover for pipe susceptible to any of these hazards shall be:

Pipe Diameter (in.)	Depth of Cover (in.)
½ through 2 ½	18
3 through 5	24
6 or more	30

At low places on the ground surface, extra fill may be placed over the pipeline to provide the minimum depth of cover. The top width of the fill shall then be no less than 10 feet and the side slopes no steeper than 6:1. If extra protection is needed at vehicle crossings, encasement pipe or other approved methods may be used.

In areas where the pipe will not be susceptible to freezing and vehicular or cultivation hazards and the soils do not crack appreciably when dry, the minimum depth of cover may be reduced to:

Pipe Diameter (in.)	Depth of Cover (in.)
½ through 1 ½	6
2 through 3	12
4 through 6	18
More than 6	24

**Trench Construction.** At any point below the top of the pipe, the trench shall be only wide enough to permit the pipe to be easily placed and joined and to allow the initial backfill material to be uniformly placed under the haunches and along the side of the pipe. The maximum trench width shall be 36 inches. If the trench is precision excavated and has a semicircular bottom that closely fits the pipe, the width shall not exceed the outside diameter of the pipe by more than 10 percent.

The trench bottom shall be uniform so that the pipe lies on the bottom without bridging. Clods, rocks, and uneven spots that can damage the pipe or cause non-uniform support shall be removed.

If rocks, boulders, or any other material that can damage the pipe are encountered, the trench bottom shall be undercut a minimum of 4 inches below final grade and filled with bedding material consisting of sands or compacted fine-grained soils.

Pipelines having a diameter of ½ through 2 ½ inches that are to be placed in areas not subject to vehicular loads and in soils that do not crack appreciably when dry may be placed using "plow-in" equipment instead of conventional trenching.

Provisions shall be made to ensure safe working conditions where unstable soil, trench, depth, or other conditions can be hazardous to personnel working in and near the trench.

**Joints and Connections.** All joints and connections shall be designed and constructed to withstand the design maximum working pressure for the pipeline without leakage and to leave the inside of the line free of any obstruction that may tend to reduce its capacity below design requirements.

All fittings, such as couplings, reduceds, bends, trees, and crosses shall be installed according to the recommendations of the pipe manufacturer.

Fittings made of steel or other metals susceptible to corrosion shall be adequately protected by plastic tape wrapping or by applying a coating having high corrosion-preventative qualities. If plastic tape wrapping is used, all surfaces shall be thoroughly cleaned and coated with a primer compatible with the tape.

**Thrust Blocks.** Thrust blocks must be formed against a solid hand-excavated trench wall undamaged by mechanical equipment. They shall be constructed of concrete, and the space between the pipe and the trench wall shall be filled to the height of the top of the pipe using only the simplest of forms.

**Initial Backfill.** Hand mechanical, or water packing methods may be used.

The initial backfill material shall be soil or sand that is free from rocks or stones larger than 1 inch in diameter. At the time of placement, the moisture content of the material shall be such that the required degree of compaction can be obtained with the backfill method to be used. The initial backfill material shall be placed so that the pipe will not be displaced, excessively deformed, or damaged.

If backfilling is done by hand or mechanical means, the initial fill shall be compacted firmly around and above the pipe as required to provide adequate lateral support to the pipe.

If the water packing method is used, the pipeline first shall be filled with water. The initial backfill before wetting shall be of sufficient depth to ensure complete coverage of the pipe after consolidation. Water packing is accomplished by adding water to diked reaches of the trench in sufficient quantity to thoroughly saturate the initial backfill without excessive pooling of water. After the backfill is saturated, the pipeline shall remain full until after the final backfill is made. The wetted fill shall be allowed to dry until firm before beginning the final backfill

**Final Backfill.** The final backfill material shall be free of large rocks, frozen clods, and other debris greater than 3 inches in diameter. The material shall be placed and spread in approximately uniform layers so that there will be no unfilled spaces in the backfill. The backfill shall be mounded above the natural ground in order to provide the minimum depth of cover after settlement. Rolling equipment shall not be used to consolidate the final backfill until the specified minimum depth of cover has been placed.

**CONSTRUCTION SPECIFICATIONS  
MD 441 – IRRIGATION SYSTEM, MICROIRRIGATION**

**1. SCOPE**

The work will consist of furnishing materials and installing all components as required to provide a complete microirrigation system as shown on the specifications and drawings.

**2. SOURCE OF WATER**

The source of water shall be as shown on the drawings, and as previously determined by the landowner. The source shall provide the design capacity for the system being installed.

**3. MATERIALS**

The materials shall be fabricated in accordance with the design and specifications and in accordance with the manufacturer's instructions. The system shall be tested to determine if the system is in proper working order, and will deliver the required capacity to meet the design use, and the specified uniformity distribution rate.

**Applicators.** Applicators shall be installed as recommended by the manufacturer. The contractor shall provide the manufacturer's performance specifications of the applicator installed in the system to the owner prior to installation. They shall be manufactured from materials resistant to the normal effects of water, weather, sun and commonly injected agricultural chemicals used for cleaning, chemigation and water amendments. Applicators placed beneath the ground surface will be placed deep enough to protect them from normal farming operations. Spray type emitters will be installed in such a manner that the wetted (P<sub>w</sub>) used in the design can be obtained.

**Pumps, Power Units and Filters.** Pumps, power units, and filters shall be set on a firm base, be placed in proper alignment, and shall meet the power, capacity, and pressure requirements specified. All pertinent safety codes and manufacturer's recommendations shall be met for the type of equipment installed.

**Pipe.** The manufacturer's performance data will be provided by contractor for pipe (tubing) used as laterals in the system and all other pipe not included in the standard for irrigation pipelines (MD430). The manufacturer's data must include the maximum allowable operating pressure and inside diameter. This pipe and tubing shall be installed as recommended by the manufacturer. A copy of the manufacturer's data shall be provided prior to installation.

Install surface drip lateral lines on, or just above, the ground along the plant row(s). Provide 2 percent extra length to surface laterals to allow for expansion and contraction of the line. Pin or anchor above-ground drip lines to prevent dislodging or movement of the line away from the plants or pots.

**Joints and Connections.** All joints and connections involved in installation of laterals to the manifold lines shall be made in accordance with the pipe manufacturer's recommendations and shall be constructed to withstand the maximum design working pressure for the pipelines without leakage. Connections of applicators to the lateral lines shall be in accordance with the manufacturer's recommendations.

**Valves.** All valves which must pass the design discharge should be equal to the size of pipe, but shall not be smaller than the size recommended by the manufacturer. The manufacturer's performance data and specifications for valves shall be provided by the contractor. The valves shall be type and of the material specified. Valves shall be installed according to manufacturer's recommendations to withstand the maximum design working pressure without damage, or leakage.

**Injectors (Chemical, Fertilizer or Pesticides) and Automatic Operating Equipment (Timer).** Where automatic equipment or injectors (chemical, fertilizer, and pesticide) have been planned for the system, it shall be located adjacent to the pump and power unit and installed in accordance with the manufacturer's recommendation. When chemicals are injected, back-flow prevention devices shall be provided.

**4. TESTING THE SYSTEM**

The system shall be thoroughly and completely tested at the design pressure for strength, proper functioning, and leakage. Any leaks shall be repaired and the system retested.

During the initial start-up, but prior to the placement of end plugs, the manifold and lateral lines shall be flushed for a sufficient time to remove any sediment or foreign material from each line.

There shall be no objectionable flow conditions at or below design capacity and all appurtenances shall perform properly.

**5. EROSION CONTROL AND WATER REMOVAL**

There may be potential for soil erosion during construction. Construction operations shall be carried out so that erosion, air, and water pollution are minimized.

**LANDOWNER – SITE NAME**

#####  
COUNTY Soil Conservation District

JOB CLASS #

TRACT #

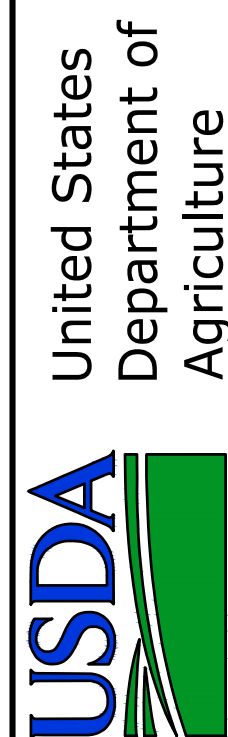

**Natural Resources  
Conservation Service**

File Name

MD\_0060\_IrrigationMicro.dwg

Drawing No.  
MD\_0060

Sheet 5 of 5

Date	_____
Designed	_____
Drawn	_____
Checked	_____
Approved	_____

\_\_\_\_\_, Maryland